

D SERIES
Dismountable Design

TVB-B12

DOUBLE
CONVOLUTION

DRAWING

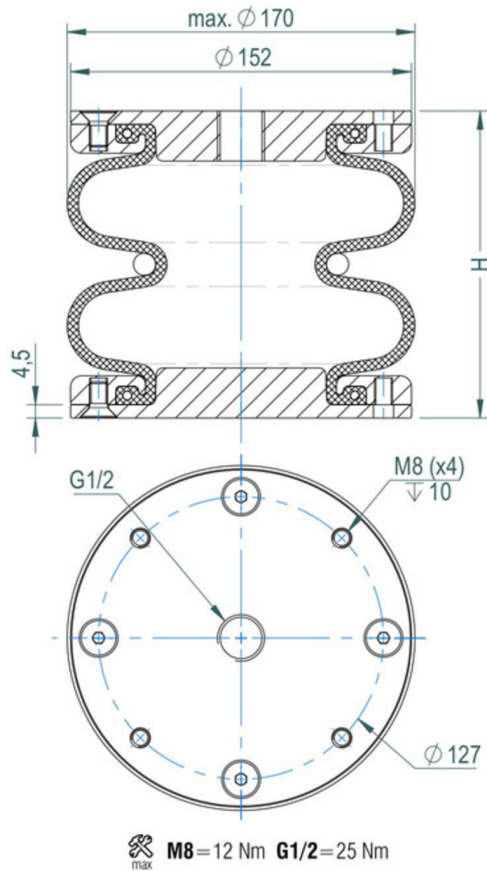

FORCE-HEIGHT CHART

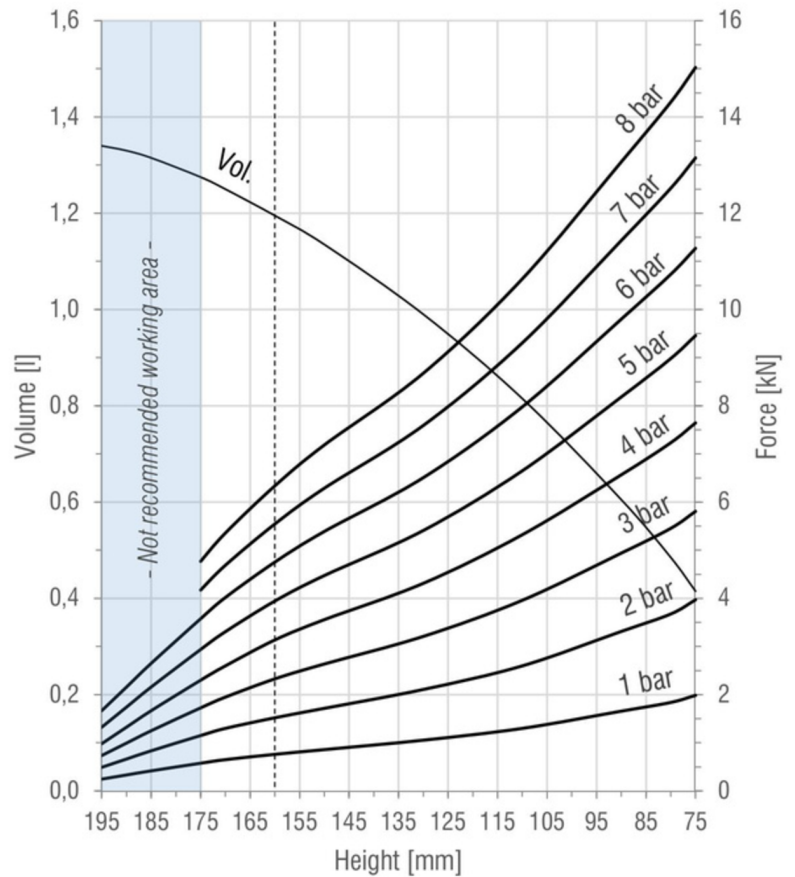

TECHNICAL DATA

PRODUCT CHARACTERISTICS

Static diameter [mm]	155
Max. diameter [mm]	170
Required space diameter [mm]	185
Min. height [mm]	75
Static height [mm]	130
Design height [mm]	160
Max. usable height [mm]	195
Max. stroke [mm]	120
Force to compress to H_{min} at 0 bar [N]	170
Weight [kg]	1,8

REFERENCES

6x2_B	Rubber bellow only
6x2_D_AL	With aluminium end closures

Designs available with stainless steel and high temperature rubber compounds. Additional designs on request.

DYNAMIC CHARACTERISTICS FOR USE AS ISOLATOR

Pressure [bar]	3	4	5	6	7	Vol. [l]
Load [kN]	2,3	3,1	3,9	4,8	5,5	1,2
Spring rate [N/mm]	57	74	90	106	123	
Natural frequency [Hz]	2,47	2,43	2,39	2,36	2,35	
Isolation rate at 10 Hz	93,5%	93,7%	93,9%	94,1%	94,1%	

Values at recommended design height H: 160 mm -----

STATIC CHARACTERISTICS FOR USE AS ACTUATOR

Pressure [bar]		3	4	5	6	7	Vol. [l]
Height H [mm]	75	5,8	7,6	9,5	11,3	13,1	0,4
	90	4,9	6,6	8,2	9,8	11,4	0,6
	110	4,0	5,3	6,6	8,0	9,3	0,8
	130	3,2	4,3	5,4	6,5	7,6	1,0
	150	2,6	3,6	4,5	5,4	6,3	1,1
	170	1,9	2,6	3,3	4,0	4,7	1,3

Force values [kN]

All Volume [l] values at 7 bar